



ULTRA TW HP

Interior wall mounted sconce with up and downlight emission.

DETAILS.

FINISH: WHITE

SIZE: Ø3 5/16" X 4 9/16" H X 4 1/16" D
40W MAX G9 120V

DOES NOT COVER US J-BOX.

***MUDKIT OR COVERPLATE AVAILABLE.**

IP20 – SUITABLE FOR DRY/DAMP LOCATIONS.

ETL LISTED

***OTHER VOLTAGES OR DIMMING OPTIONS AVAILABLE.**

ULTRA TW HP

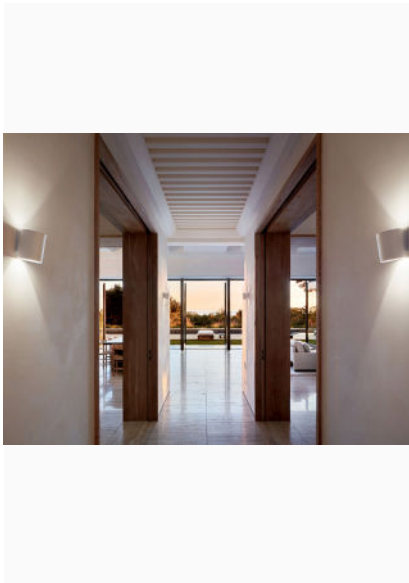
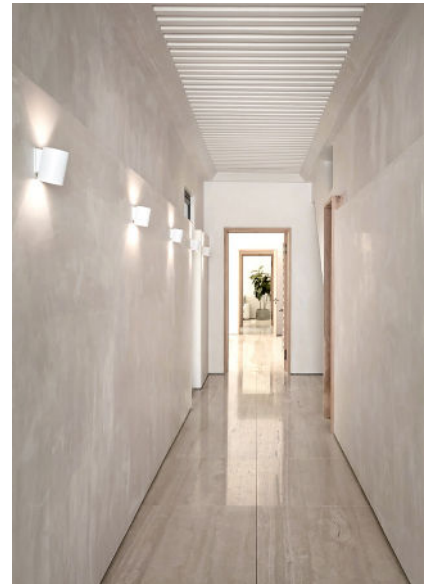

ULTRA TW HP



ULTRA TW HP◇
 6 279 51 40 ◇
 ◇ = W

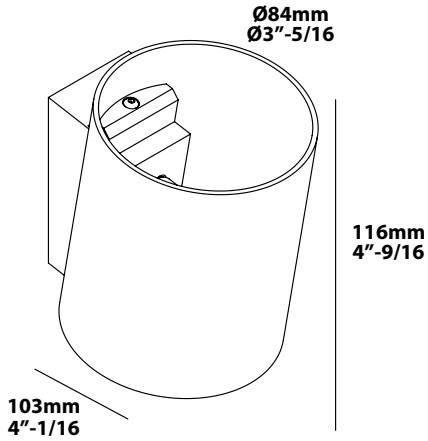
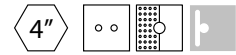

Application

Wall surface mounted
 Installation to a standard 4" octagonal box with optional coverplate or Mud kit installation
 For indoor use only

Color Finish

W - White

Light source

1 x G9 (T4) max. 40W

Product description

Powder coated aluminum base
 Input voltage: 120V / 60Hz
 Lampholder: G9
 Suitable for dry or damp location
 Protected against solid objects greater than 12 mm → IP20
 Weight: 0,7lbs 0,3kg

Options (not supplied)

MUD KIT 5 A / W	6 207 02 05 A / W
COVERPLATE S 105	6 204 99 105