



MAIJA

Metallic lampshade and circular ceiling rosette with brass structure finished in matte. The collection originally designed in 1955, now incorporates built-in adjustable LED technology, capable of blending functionality and intimacy at the same time. Re-edited in 2 sizes, with both models having an inner white glass diffuser to help filter light. Also available as table and floor lamp.

Design by: Ilmari Tapiovaara. 1955

DETAILS.

FINISHES AVAILABLE IN:

WHITE

NUDE ROSE (MAIJA 15 ONLY.)

DIFFUSER FINISH: WHITE TRANSLUCENT GLASS

MAIJA 15 SHADE SIZE: Ø5.9" X 5.5" H

CANOPY: Ø4.3" X 2.3" H

DROP: 17.7" MIN.-124" MAX.

6W LED 2700K 289 LM

CRI 90 / 1-10V DIMMABLE

WEIGHT: 3.1 LBS (UNPACKED)

MAIJA 30 SHADE SIZE: Ø11.8" X 10.9" H

CANOPY: Ø4.3" X 2.3" H

DROP: 23.6" MIN.-130" MAX.

8.4W LED 2700K 329 LM

CRI 90 / 1-10V DIMMABLE

WEIGHT: 6.4 LBS (UNPACKED)

ELECTRICAL CABLE LENGTH: 118"

RATED IP20 – FOR INDOOR USE.

UL LISTED

MAIJA



MAIJA



Maija

Ilmari Tapiovaara. 1955
Pendant lamps



Maija 15

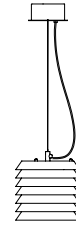

A

Maija 30

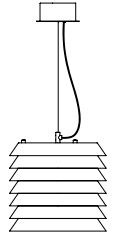

B



Tapiovaara said that “it is impossible to create a new object without a point of reference, and nature is the best and closest manual for the industrial designer. Whether in terms of the object’s purpose, that is, its functional requirements; or in terms of shape, colour, material and adequate proportion”^W. In 1955, when Alvar Aalto was the dominant figure of Helsinki’s cultural life, Ilmari Tapiovaara presented himself as the first Finnish non-architect designer. An expert in chairs and furniture, he created his sole and unique household lamp: Maija.

The Maija collection conveys the feeling of light in Baltic cities, where the streets are barely illuminated, apart from the light beaming through the windows of homes and shops: from the inside, outwards. Inspired by this, Tapiovaara created a honeycomb structure composed of stacked metal discs that filters out its happy inner light.

A striking luminous object, table, floor or pendants lamps. The pendant version has been reedited in two sizes, with 15 cm or 30 cm diameter discs. Both models feature an interior white glass diffuser that filters the light; they can be used as single units or in a sequence. The Maija family is part of our Design Classics collection, a series of objects created at different times during the Modernist era.

General description:

Metallic lampshade and circular canopy finished in whitematte or nude rose (Maija 15).
Brass structure finished in matte.
Diffuser in white translucent glass.
Suitable for Outlet Box (UL market).
Electric cable length: 3 m / 118.1”

Approximate weight (unpacked):

(A) 1,4 kg / 3.1 lb
(B) 2,9 kg / 6.4 lb

Maija

Ilmari Tapiovaara. 1955
Pendant lamps

Technical information:

Light source included (dimmable).
LED Module

(A) Maija 15:

Rated input wattage: 6 W
Operating current: 500 mA
Colour Temp. : 2.700 K
CRI: 90
Lifetime: 40.000 h
Luminous flux: 289 lm

(B) Maija 30:

Rated input wattage: 8,4 W
Operating current: 700 mA
Colour Temp. : 2.700 K
CRI: 90
Lifetime: 40.000 h
Luminous flux: 329 lm

Built-in adjustable LED.

Suitable for dimming 1-10V. (Not included external dimmer switch 1-10V).

Energy efficiency class (E.E.C): A++... A.

Suitable only for indoor use.

Input voltage : 90 ~ 305 Vac.

(50 Hz / 60 Hz). According to destination.

Model A: Maija 15

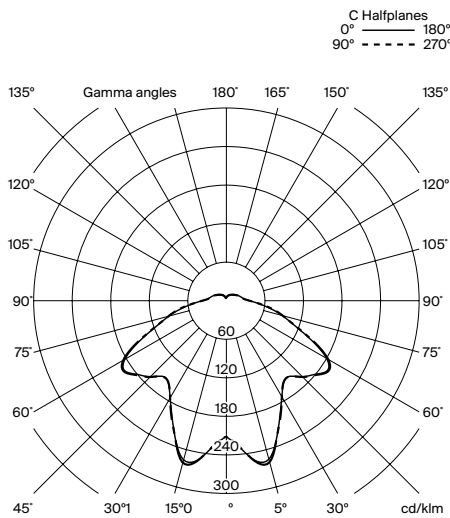

Model B: Maija 30

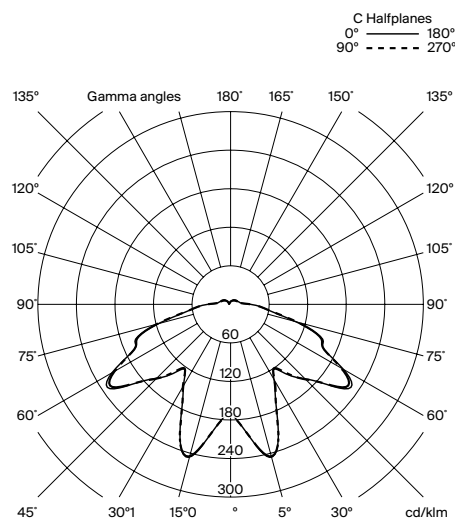

Regulations:

CE
UNE-EN 60598
UNE-EN 55015
UNE-EN 60529
UNE-EN 62031
UNE-EN 61000-3-2
UNE-EN 61347-2-13

UL

I I P L

PLUGLIGHTING.COM
INFO@PLUGLIGHTING.COM

5665 MELROSE AVENUE
STE 108 LOS ANGELES 90038

P. 323 467 5635
F. 323 467 5634

Maija

Ilmari Tapiovaara. 1955
Pendant lamps

Model A: Maija 15

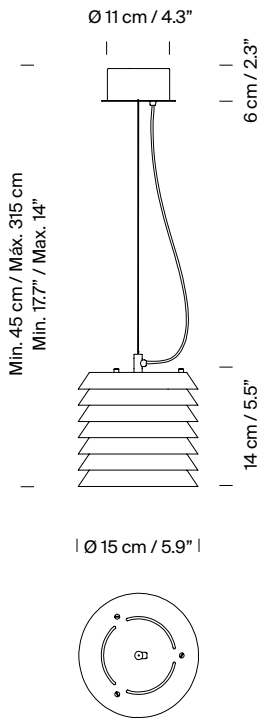

Model B: Maija 30

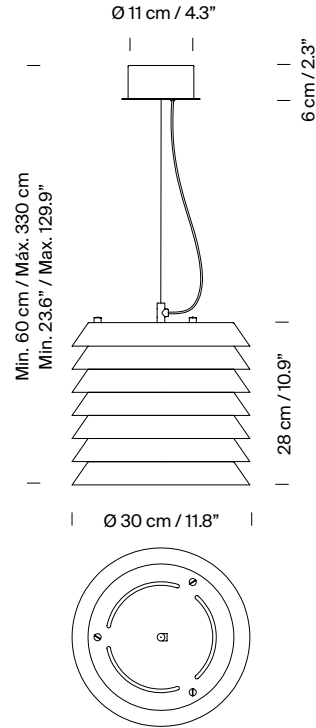

Collection:

Table lamps

Floor lamps

Pendant lamps



Maija



Maija



Maija